

1 3/4" BORE STAINLESS STEEL CYLINDER



SDR-28-□-□

Double Acting



Mount: Stud **Standard Stroke Lengths:** 1/2", 1", 1-1/2", 2", 3", 4", 5", 6"
Type: Rotating Rod **Maximum Stroke:** 39"
Options: C, F, R, M, W, V, P6, P7, P8, S, N

Bumpers are standard

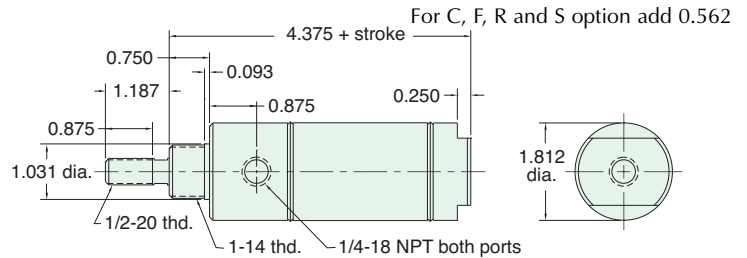

Nut included, but not shown on drawing
 C, F, & R options use side ported rear head

UDR-28-□-□

Double Acting



Mount: Universal **Standard Stroke Lengths:** 1/2", 1", 1-1/2", 2", 3", 4", 6", 8", 10", 12"
Type: Rotating Rod **Maximum Stroke:** 37"
Options: C, F, R, M, W, V, P2, P3, P4, P5, P6, P7, P8, N

Bumpers are standard

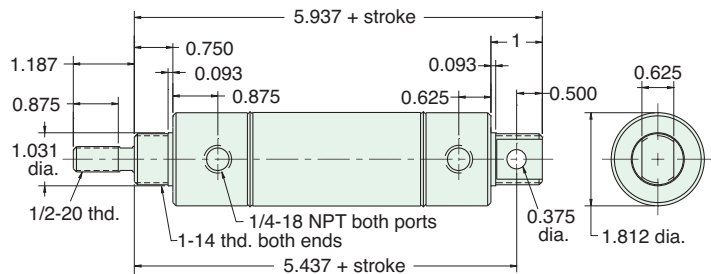

Furnished without nut(s). See Chart on Page 53.

SDD-28-□-□

Double Acting



Mount: Stud **Standard Stroke Lengths:** 1", 2", 3", 4", 5", 6", 8", 10", 12"
Type: Double Rod **Maximum Stroke:** 18"
Options: C, F, M, W, V, P6, P7, P8, N

Bumpers are standard

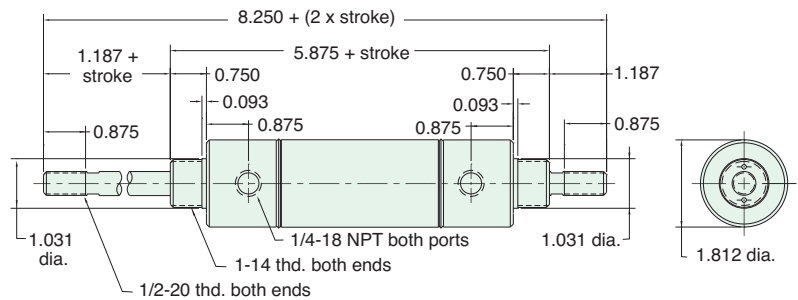

Nuts included, but not shown on drawing

SRR-28-□-□

Reverse Acting



Mount: Stud **Standard Stroke Lengths:** 1/2", 1", 1-1/2", 2", 3", 4"
Type: Rotating Rod **Spring Compressed:** 24 lbs. **Spring At Rest:** 11 lbs.
Options: M, W, V, N

Bumpers are standard

For M option add 0.125

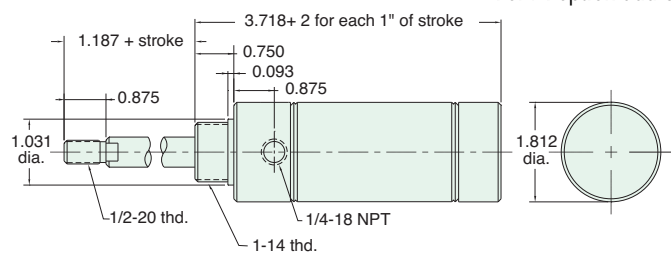

Nut included, but not shown on drawing